

HAPAS

Roads and Bridges

Polypipe Civils Ltd

Charnwood Business Park
North Road
Loughborough
Leicestershire LE11 1LE

Tel: 01509 615100 Fax: 01509 265945

e-mail: civilsales@polypipe.com

website: www.polypipe.com



Agrément Certificate
No 02/H068 Product Sheet 2

RIDGIDRAIN ADVANCED DRAINAGE SYSTEM

PRODUCT SHEET 2 – RIDGIDRAIN 400 MM TO 600 MM PIPES AND COUPLERS

This Certificate is issued under the Highway Authorities' Product Approval Scheme (HAPAS) by the British Board of Agrément (BBA) in conjunction with the Highways Agency (HA) (acting on behalf of the overseeing organisations of the Department for Transport; the Scottish Executive; the Welsh Assembly Government; the Department for Regional Development, Northern Ireland), the County Surveyors' Society, the Local Government Technical Advisers' Group, and industry bodies. HAPAS Agrément Certificates are normally each subject to a review every five years.

PRODUCT SCOPE AND SUMMARY OF CERTIFICATE

This Certificate relates to Ridgidrain 400 mm to 600 mm Pipes and Couplers, for use as filter and carrier pipes for highway drainage.

AGRÉMENT CERTIFICATION INCLUDES:

- factors relating to compliance with HAPAS requirements
- factors relating to compliance with Regulations where applicable
- independently verified technical specification
- assessment criteria and technical investigations
- design considerations
- installation guidance
- regular surveillance of production
- formal five-yearly review.

KEY FACTORS ASSESSED

Strength — the pipes and couplers have adequate strength to resist loads associated with installation and service (see section 4).

Performance of joints — the system will remain watertight under normal service conditions (see section 5).

Durability — the system will have a service life in excess of 50 years (see section 10).



The BBA has awarded this Agrément Certificate for Ridgidrain 400 mm to 600 mm Pipes and Couplers to Polypipe Civils Ltd as fit for their intended use provided they are installed, used and maintained as set out in this Agrément Certificate.

On behalf of the British Board of Agrément

Head of Approvals
— Engineering

Chief Executive

Date of First issue: 27 March 2002
Date of Third issue: 16 June 2008

The BBA is a UKAS accredited certification body — Number 113. The schedule of the current scope of accreditation for product certification is available in pdf format via the UKAS link on the BBA website at www.bbacerts.co.uk

Readers are advised to check the validity of this Agrément Certificate by either referring to the BBA's website (www.bbacerts.co.uk) or contacting the BBA direct.

British Board of Agrément
Bucknalls Lane
Garston, Watford
Herts WD25 9BA

©2008

tel: 01923 665300
fax: 01923 665301
e-mail: mail@bba.star.co.uk
website: www.bbacerts.co.uk

HAPAS Requirements

Requirements

The general requirements for drains are contained in the Manual of Contract Documents for Highway Works (MCHW)⁽¹⁾, Volume 1 and Volume 2.

The general requirements for structured wall pipes and fittings are contained in the MCHW Volume 1, Clause 518.

Further information and guidance is given in MCHW, Volume 3, Drawing Numbers F1 and F2.

Additional site requirements may be included on particular contracts.

(1) The MCHW is operated by the Overseeing Organisations : The Highways Agency (HA), Transport Scotland, the Welsh Assembly Government and The Department for Regional Development (Northern Ireland).

Regulations

Construction (Design and Management) Regulations 2007

Construction (Design and Management) Regulations (Northern Ireland) 2007

Information in this Certificate may assist the client, CDM co-ordinator, designer and contractors to address their obligations under these Regulations.

See sections: 2 Delivery and site handling (2.1) and General (1).

General

This Certificate relates to Ridgidrain 400 mm to 600 mm Pipes and Couplers, polypropylene copolymer filter and carrier pipes in diameters of 400 mm, 450 mm, 500 mm and 600 mm.

The pipes and couplers comply with Manual of Contract Documents for Highway Works (MCHW), Volume 1, Clause 518, and are for use in highway drainage for the collection and disposal of surface and sub-surface water.

Technical Specification

1 Description

1.1 Ridgidrain filter and carrier (perforated and unperforated) pipes are manufactured with a black polypropylene copolymer outer layer and a blue polypropylene copolymer inner layer, by a twin extrusion process. The inner layer is available in other colours. For information, contact the manufacturer. Two polypropylene copolymer pipes are extruded simultaneously, one inside the other, and heat-welded together in one continuous process.

1.2 Ridgidrain pipes are supplied in sizes of 400 mm, 450 mm, 500 mm and 600 mm.

1.3 The products tested and covered by this Certificate are manufactured from material with the specification given in Table 1.

1.4 The outer wall is corrugated and the inner wall is smooth finished. Details and dimensions are given in Table 2 and Figure 1.

1.5 All sizes of pipe can be supplied with a plain end and a welded integral socket end. The integral socket end is designed to connect with the plain end or spigot pipe end and is the same as half the coupler (see Table 3 and Figure 2).

1.6 Black polypropylene copolymer couplers are manufactured by the Certificate holder and are available for each size of pipe (see Table 4 and Figure 2).

| Table 1 Material properties/specification ⁽¹⁾ | | | Table 2 Pipe dimensions | | | | | | | |
|--|-----------------------|--|--|--|--|----------------------|----------------------|----------------------|-------------------------------------|--|
| Property | Test method reference | Specification | Nom ⁽¹⁾ internal pipe diameter, d_1 (mm) | Min ⁽²⁾ internal pipe diameter (mm) | Nom ⁽¹⁾ external pipe diameter, d_2 (mm) | t_1 min (mm) | t_2 min (mm) | t_3 min (mm) | Nom ⁽¹⁾ length (m) | Nom ⁽¹⁾ weight (kgm ⁻¹) |
| Tensile properties | EN 638, ISO 527-2 | Sample 1B at 50 mm min ⁻¹ ≥ 21 MPa ≥ 4 min | 400 | 395 | 457.5 | 1.7 | 3.0 | 1.5 | 6 | 7.3 |
| Oxygen induction time | EN 728 | < 1.8 g (10 min) ⁻¹ | 450 | 445 | 512.25 | 1.7 | 3.0 | 1.5 | 6 | 9.4 |
| Melt flow rate | ISO 1133 | ≥ 890 kgm ⁻³ | 500 | 496 | 569.5 | 1.8 | 3.2 | 1.6 | 6 | 11.0 |
| Density | ISO 1183 | 150°C ± 2°C (pass) | 600 | 588 | 674.5 | 1.8 | 3.3 | 1.7 | 6 | 14.0 |
| Heat reversion | ISO 12091 | 150°C ± 2°C (pass) | | | | | | | | |
| Effects of heating (injection moulded fittings only) | EN 763 | 150°C ± 2°C (pass) | | | | | | | | |

(1) This table is in the format of Appendix 5/7 of MCHW, Volume 2. It is used to satisfy Clause 518.2 of MCHW, Volume 1.

Figure 1 Ridgidrain pipe

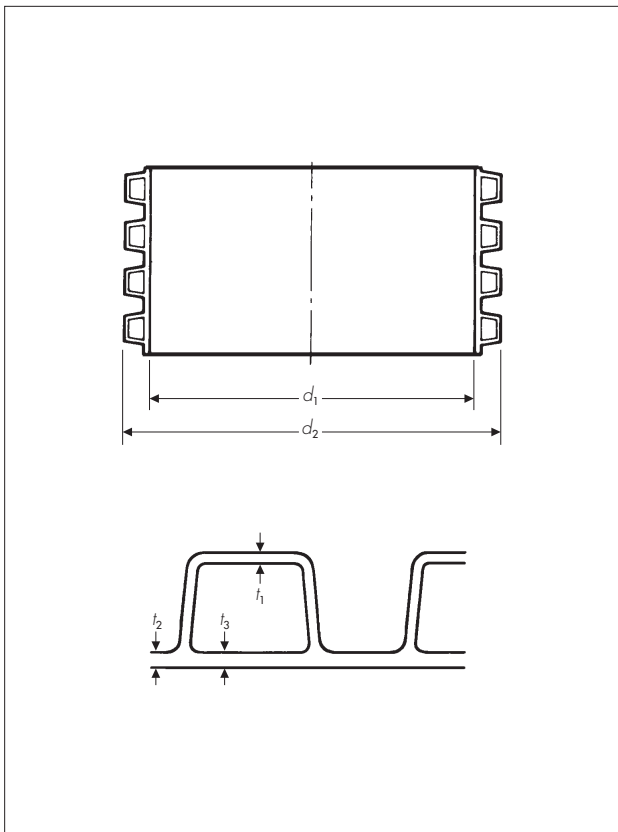

Table 3 Integral socket dimensions

| Nominal internal pipe diameter, d_1 (mm) | Nominal socket diameter, d_3 (mm) | Nominal socket depth, L_1 (mm) | Nominal seal height (h) (mm) |
|--|-------------------------------------|----------------------------------|----------------------------------|
| 400 | 461 | 196 | 32 |
| 450 | 517 | 215 | 35 |
| 500 | 574 | 240 | 38 |
| 600 | 678 | 275 | 44 |

Table 4 Coupler dimensions

| Nominal pipe size (mm) | Nominal internal diameter, d_3 (mm) | Nominal external diameter, d_4 (mm) | Nominal length (L) (mm) | Nominal seal height (h) (mm) |
|------------------------|---------------------------------------|---------------------------------------|-----------------------------|----------------------------------|
| 400 | 461 | 479 | 400 | 32 |
| 450 | 517 | 529 | 438 | 35 |
| 500 | 574 | 583 | 489 | 38 |
| 600 | 678 | 688 | 560 | 44 |

Figure 2 Welded integral socket and couplers

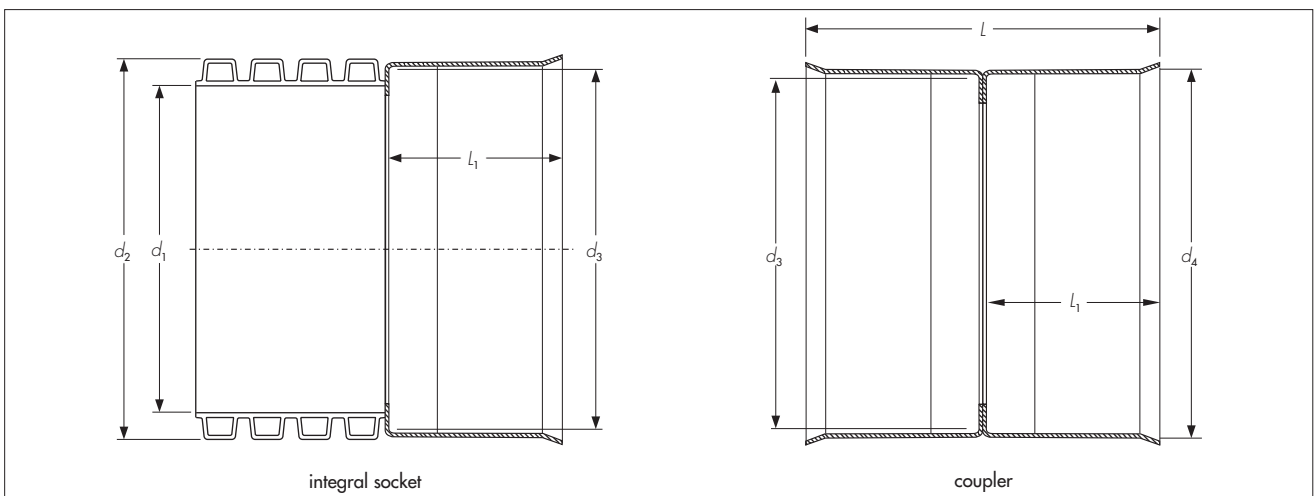

1.7 Each coupler requires two rubber seals which can be obtained from the Certificate holder, manufactured to BS EN 681-1 : 1996. The seals (see Figure 3) must be fitted in accordance with the installation instructions to ensure a watertight joint.

Figure 3 Seals

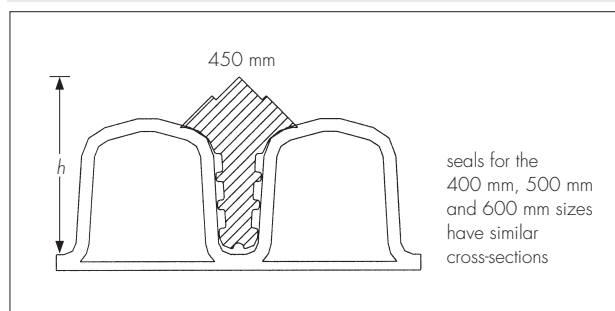

1.8 Pipes can be supplied either perforated or unperforated. Perforated pipe is available with the slots in the dwell between corrugations equally spaced around the circumference and offset symmetrically for alternate dwells along the pipe length (see Tables 5 and 6 and Figure 4). Alternatively, the slots are located on one half only of the pipe and thus the permeable area is approximately halved.

Table 5 Perforated pipe details — fully perforated

| Nominal internal pipe diameter (mm) | No of slots per dwell | No of dwells per metre | Slot length (range) (mm) | Slot width (range) (mm) | Permeable area (minimum) (mm ² m ⁻¹) |
|-------------------------------------|-----------------------|------------------------|--------------------------|-------------------------|---|
| 400 | 2 | 20 | 70–90 | 3–4 | 8400 |
| 450 | 2 | 26 | 70–90 | 3–4 | 10 920 |
| 500 | 2 | 22 | 70–90 | 3–4 | 9240 |
| 600 | 2 | 19 | 80–100 | 3–4 | 9120 |

Table 6 Perforated pipe details — half perforated

| Nominal internal pipe diameter (mm) | No of slots per dwell | No of dwells per metre | Slot length (range) (mm) | Slot width (range) (mm) | Permeable area (minimum) (mm ² m ⁻¹) |
|-------------------------------------|-----------------------|------------------------|--------------------------|-------------------------|---|
| 400 | 1 | 20 | 70–90 | 3–4 | 4200 |
| 450 | 1 | 26 | 70–90 | 3–4 | 5460 |
| 500 | 1 | 22 | 70–90 | 3–4 | 4620 |
| 600 | 1 | 19 | 70–90 | 3–4 | 4560 |

Figure 4 Details of perforations

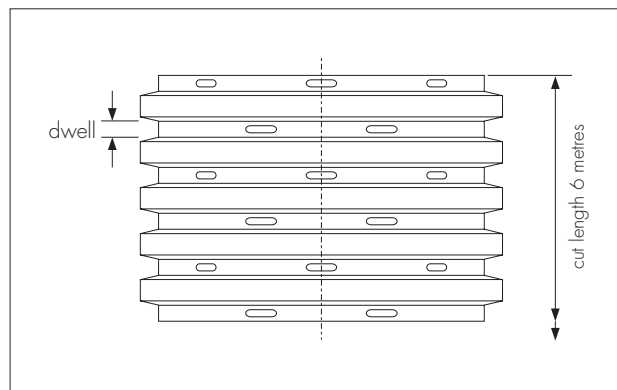

1.9 Continuous quality control is exercised during manufacture. Checks include:

Pipes

- dimensional accuracy
- impact resistance
- short-term stiffness.

Couplers

- dimensional accuracy
- impact resistance.

1.10 A label bearing the BBA identification mark incorporating the number of this Certificate is attached to each pipe length and fitting or to each pack of pipes.

2 Delivery and site handling

2.1 Handling, storage and transportation should be in accordance with BS 5955-6 : 1980.

2.2 When long-term storage is envisaged, Ridgidrain ADS perforated and unperforated pipes and couplers must be protected from direct sunlight. If protection cannot be provided, consideration must be given to the effects of daily exposure to direct sunlight:

- up to 3 months — negligible UV degradation but possible extreme surface temperatures of up to 80°C may cause some localised distortion
- 3 months to 12 months — may have significant effect on the impact resistance and physical properties
- over 12 months — damage will occur unless protection provided.

2.3 The manufacturer has the option of adding chemicals to provide enhanced UV stability on request.

2.4 Pipes should be stored on a flat surface. They are generally delivered as loose lengths and should not be stacked more than 4 m high. Care should be taken not to drop pipes or couplers on their ends, particularly during cold weather conditions.

Assessment and Technical Investigations

The following is a summary of the assessment and technical investigations carried out on Ridgidrain 400 mm to 600 mm Pipes and Couplings.

Design Considerations

3 General

Ridgidrain 400 mm to 600 mm Pipes and Couplings (perforated and unperforated), comply with the requirements of the MCHW, Volume 1, Clause 518.5 for pipe, Clause 518.6 for couplers and Clause 518.7 for the system. When installed in accordance with the recommendations given in this Certificate, they are suitable for use in highways for the collection and disposal of surface and sub-surface water.

4 Strength

4.1 The pipes have a ring stiffness in excess of 8 kNm^{-2} and a creep ratio of less than 4 and have adequate resistance to static loads.

4.2 The pipes have adequate resistance to impact loads to which they may be subjected during installation and in service.

4.3 The pipes can be used as an alternative to the plastic pipes for surface water drains listed in Table 5/1 of the MCHW, Volume 1, and for safe bedding depth purposes may be assumed to have a standard dimension ratio (SDR) equivalent of not greater than 41.

5 Performance of joints

5.1 Joints on filter pipes made from pipe and couplers without the rubber seals are not partially watertight as defined in the MCHW, Volume 1, Clause 504.3.

5.2 Correctly made, the joints constructed from pipe and couplers with rubber seals remain watertight when subjected to deflection and distortion, and comply with the MCHW, Volume 1, Clauses 504.3 and 518.7 (see section 13).

6 Water infiltration

The slot area for the pipes exceeds the HA minimum requirement given in the MCHW, Volume 1, Clause 518.3 of 1000 mm^2 per metre length (see Tables 5 and 6).

7 Flow characteristics

7.1 The pipes will have normal flow characteristics associated with PVC-U pipes.

7.2 Full-bore velocities are available from the *Tables for the Hydraulic Design of Pipes, Sewers and Channels*, Volume 2, 8th Edition by H R Wallingford and D I H Barr. The values are based on the Colebrook-White equation. An appropriate value of roughness coefficient should be selected when designing the drainage system. For new pipes, a value of 0.006 mm is applicable, but for designs, a value of 0.6 mm is generally used.

8 Practicability of installation

The pipes are installed easily using traditional drain-laying methods in accordance with HA requirements and MCHW, Volume 1, Clauses 503, 505, 518.7 and 518.8. The lengths in which the pipes are available and their lightness in weight are a significant advantage in handling and installation. Jointing of the pipes is achieved easily.

9 Maintenance

9.1 The slots are designed to restrict the ingress of silt into the drains.

9.2 Access to the system for cleaning should be provided by conventional methods.

9.3 The system can be rodded easily using flexible drain rods. In common with other standard plastic drainage systems, toothed root cutters and rods with metal ferrules, as used with some mechanical clearing systems, could damage the pipes and couplers and should not be used.

9.4 Tests indicate that the pipes have adequate resistance to water cleansing using pressure jetting equipment (see section 13.1). It is recommended that low pressure, high volume systems are utilised in accordance with the MCHW, Volume 1, Clause 520.

10 Durability

In the opinion of the BBA, when used in the context of this Product Sheet, the material from which the pipes and couplers are manufactured will not significantly deteriorate and the anticipated life of the system will be in excess of 50 years.

11 General

Ridgidrain 400 mm to 600 mm Pipes and couplings (perforated and unperforated) must be installed in accordance with HA requirements and MCHW, Volume 1, Clauses 503, 505, 518.7 and 518.8.

12 Procedures

12.1 For typical laying, trench and backfilling specification details reference should be made to Figure 5 and the MCHW, Volume 3, Drawing Nos F1 (Type T and S) and F2 (Type G, H and I).

12.2 Pipes are cut easily using conventional hand tools, and should be cut square between the corrugations.

12.3 For a watertight joint, the pipe ends and coupler should be cleaned and a rubber seal fitted externally between the first and second corrugation in the pipe. The seal and inside of the coupler should be lubricated and the pipe pushed fully home to the central register, either by hand or using a lever if necessary.

12.4 Ridgidrain ADS perforated and unperforated pipes and couplers must be protected against damage from site construction traffic.

12.5 Care should be taken during backfill to maintain the line and level of the pipeline. If necessary, the pipe should be restrained to prevent uplift.

Figure 5 Trench and bedding details

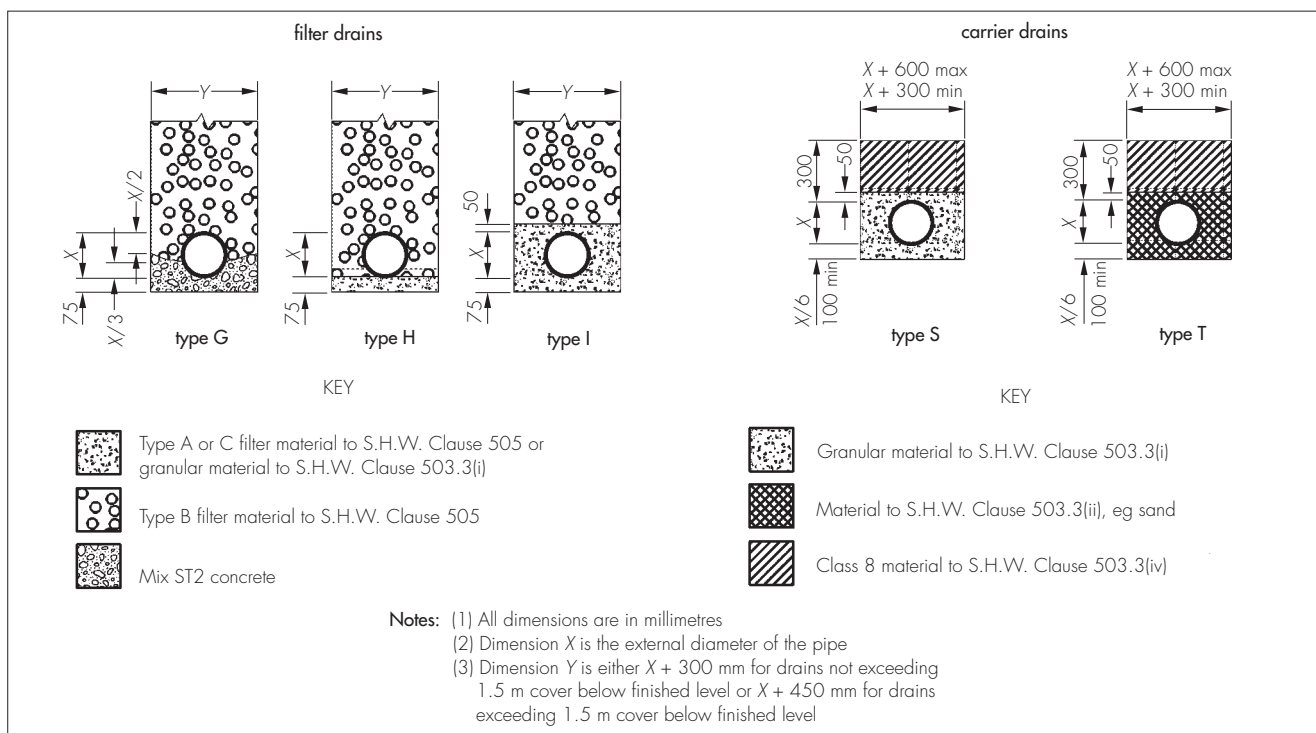

Technical Investigations

13 Tests

13.1 Tests were carried out to determine compliance with MCHW, Volume 1, Clause 518.5, on:

- determination of ring stiffness to BS EN ISO 9969 : 1995
- creep ratio to BS EN ISO 9967 : 1995
- impact strength at 0°C and 23°C to BS EN 1411 : 1996 with a d25 striker of 1.0 kg mass
- rodding resistance to MCHW, Volume 1, Clause 518.12
- water jetting WRc method.

13.2 Tests were carried out on joined pipe to establish compliance with MCHW, Volume 1, Clause 518.7, on:

- leaktightness of joints to BS EN 1277 : 1996 when subjected to diameter distortion and angular deflection from 0.5 bar to -0.3 bar
- insertion force (ease of jointing)
- resistance to rodding.

13.3 Tests were carried out to establish the dimensional accuracy of the pipe, coupler and ring seal.

14 Investigations

- 14.1 An examination was made of data in relation to the effect of the production tolerances on the performance of the products.
- 14.2 An evaluation of existing data was made to assess material properties, chemical resistance and durability.
- 14.3 Calculations were carried out to determine the slot area.
- 14.4 A visit to a site in progress was carried out to assess the practicability of installation.
- 14.5 The manufacturing process was examined, including the methods adopted for quality control, and details were obtained of the quality and composition of the materials used.

Bibliography

- BS 5955-6 : 1980 *Plastics pipework (thermoplastics materials) — Code of practice for the installation of unplasticized PVC pipework for gravity drains and sewers*
- BS EN 681-1 : 1996 *Elastomeric seals — Material requirements for pipe joint seals used in water and drainage applications — Vulcanized rubber*
- BS EN 1277 : 1996 *Plastics piping systems. Thermoplastics piping systems for buried non-pressure applications. Test methods for leaktightness of elastomeric sealing ring type joints*
- BS EN 1411 : 1996 *Plastics piping and ducting systems. Thermoplastics pipes. Determination of resistance to external blows by the staircase method*
- BS EN ISO 9967 : 1995 *Thermoplastic pipes. Determination of creep ratio*
- BS EN ISO 9969 : 1995 *Thermoplastic pipes. Determination of ring stiffness*
- EN 638 : 1994 *Plastics piping and ducting systems — Thermoplastics pipes — Determination of tensile properties*
- EN 728 : 1997 *Plastics piping and ducting systems — Polyolefin pipes and fittings — Determination of oxidation induction time*
- EN 763 : 1994 *Plastics piping and ducting systems — Injection moulded thermoplastics fittings — Test method for visually assessing effects of heating*
- ISO 527-2 : 1993 *Plastics — Determination of tensile properties — Test conditions for moulding and extrusion plastics*
- ISO 1133 : 1997 *Plastics — Determination of the melt mass-flow rate (MFR) and the melt volume-flow rate (MVR) of thermoplastics*
- ISO 1183 : 1970 *Method for determining the density and relative density (specific gravity) of plastics excluding cellular plastics*
- ISO 12091 : 1995 *Structural wall thermoplastics pipes — Oven test*
- Manual of Contract Documents for Highway Works, Volume 1 *Specification for Highway Works*, August 1998 (as amended)
- Manual of Contract Documents for Highway Works, Volume 2 *Notes for Guidance on the Specification for Highway Works*, August 1998 (as amended)
- Manual of Contract Documents for Highway Works, Volume 3 *Highway Construction Details*, March 1998 (as amended)

15 Conditions

15.1 This Certificate:

- relates only to the product/system that is named and described on the front page
- is granted only to the company, firm or person named on the front page — no other company, firm or person may hold or claim any entitlement to this Certificate
- is valid only within the UK
- has to be read, considered and used as a whole document — it may be misleading and will be incomplete to be selective
- is copyright of the BBA
- is subject to English law.

15.2 References in this Certificate to any Act of Parliament, Statutory Instrument, Directive or Regulation of the European Union, British, European or International Standard, Code of Practice, manufacturers' instructions or similar publication, are references to such publication in the form in which it was current at the date of this Certificate.

15.3 This Certificate will remain valid for an unlimited period provided that the product/system and the manufacture and/or fabrication including all related and relevant processes thereof:

- are maintained at or above the levels which have been assessed and found to be satisfactory by the BBA
- continue to be checked as and when deemed appropriate by the BBA under arrangements that it will determine
- are reviewed by the BBA as and when it considers appropriate
- remain in accordance with the requirements of Highways Authorities' Product Approval Scheme.

15.4 In granting this Certificate, the BBA is not responsible for:

- the presence or absence of any patent, intellectual property or similar rights subsisting in the product/system or any other product/system
- the right of the Certificate holder to manufacture, supply, install, maintain or market the product/system
- individual installations of the product/system, including the nature, design, methods and workmanship of or related to the installation
- the actual works in which the product/system is installed, used and maintained, including the nature, design, methods and workmanship of such works.

15.5 Any information relating to the manufacture, supply, installation, use and maintenance of this product/system which is contained or referred to in this Certificate is the minimum required to be met when the product/system is manufactured, supplied, installed, used and maintained. It does not purport in any way to restate the requirements of the Health & Safety at Work etc Act 1974, or of any other statutory, common law or other duty which may exist at the date of this Certificate; nor is conformity with such information to be taken as satisfying the requirements of the 1974 Act or of any statutory, common law or other duty of care. In granting this Certificate, the BBA does not accept responsibility to any person or body for any loss or damage, including personal injury, arising as a direct or indirect result of the manufacture, supply, installation, use and maintenance of this product/system.